

C9-1

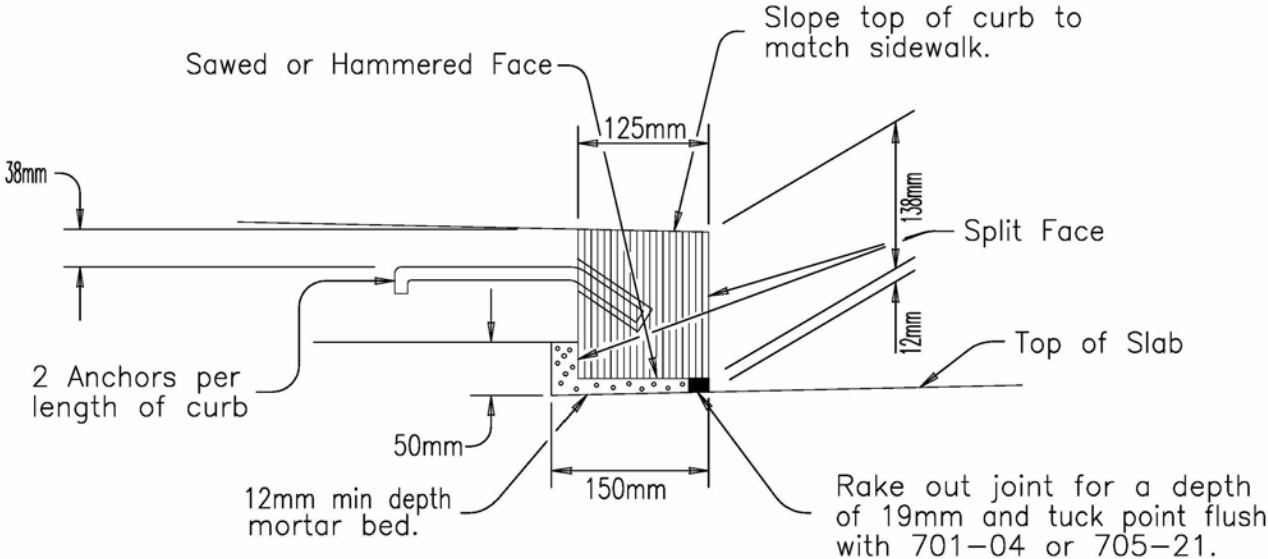

Item 609.0302M

DETAIL OF GRANITE CURB – TYPE F1

Not to Scale

J:\ORANGEBK\METRIC\C9 CURB

C9-2

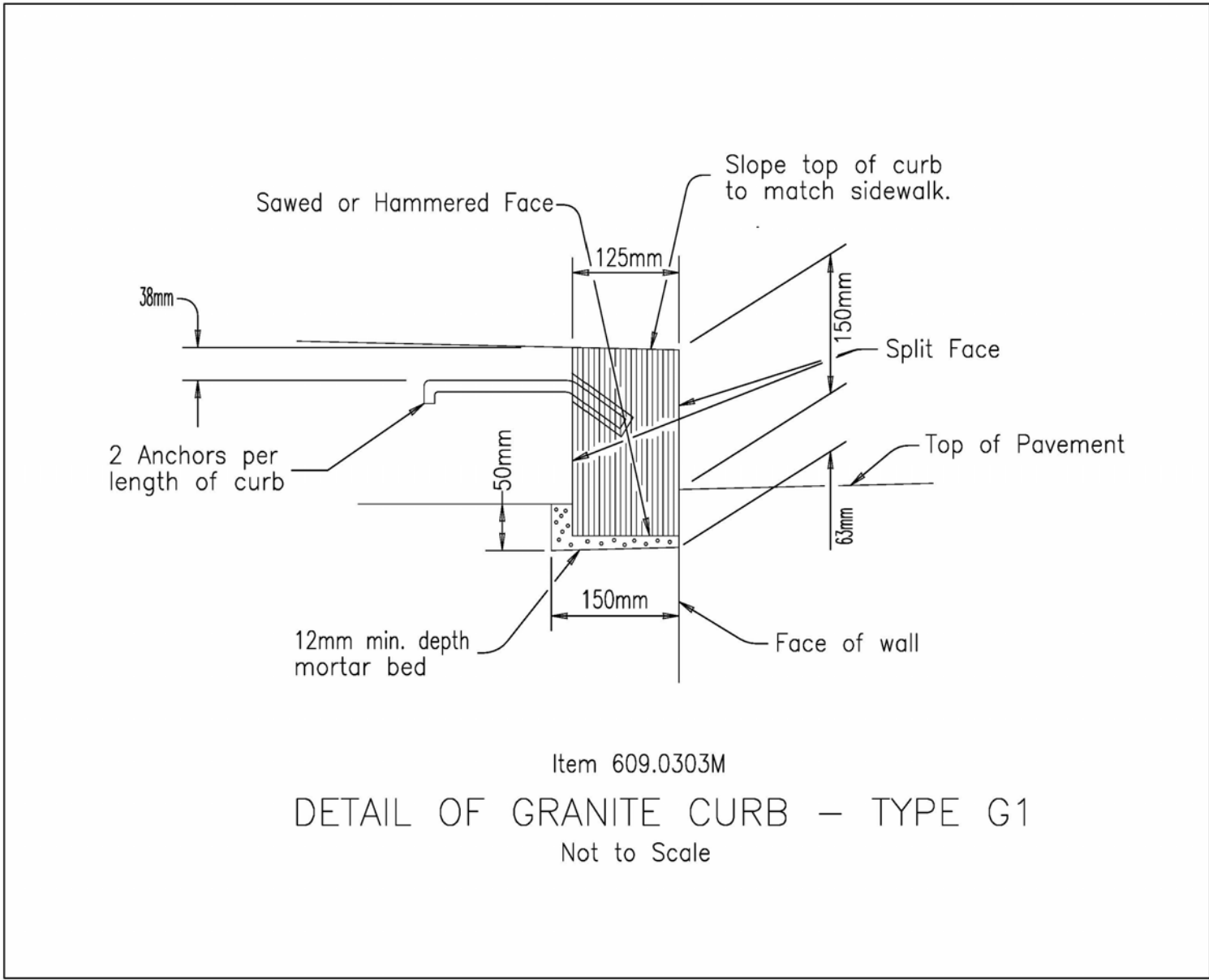

Item 609.0303M

DETAIL OF GRANITE CURB - TYPE G1

Not to Scale

J:\ORANGEBK\METRIC\C9 CURB

C9-3

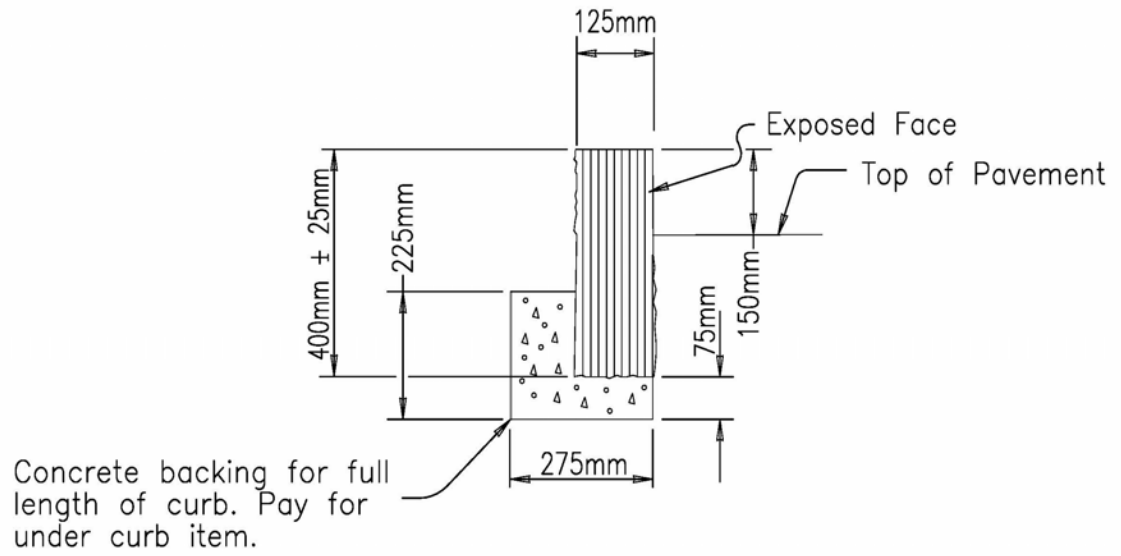

Item 609.0301M
SAWED OR HAMMERED TOP, QUARRY SPLIT FACE
DETAIL OF GRANITE CURB – TYPE A
Not to Scale

J:\ORANGE\BK\METRIC\C9 CURB

C9-4

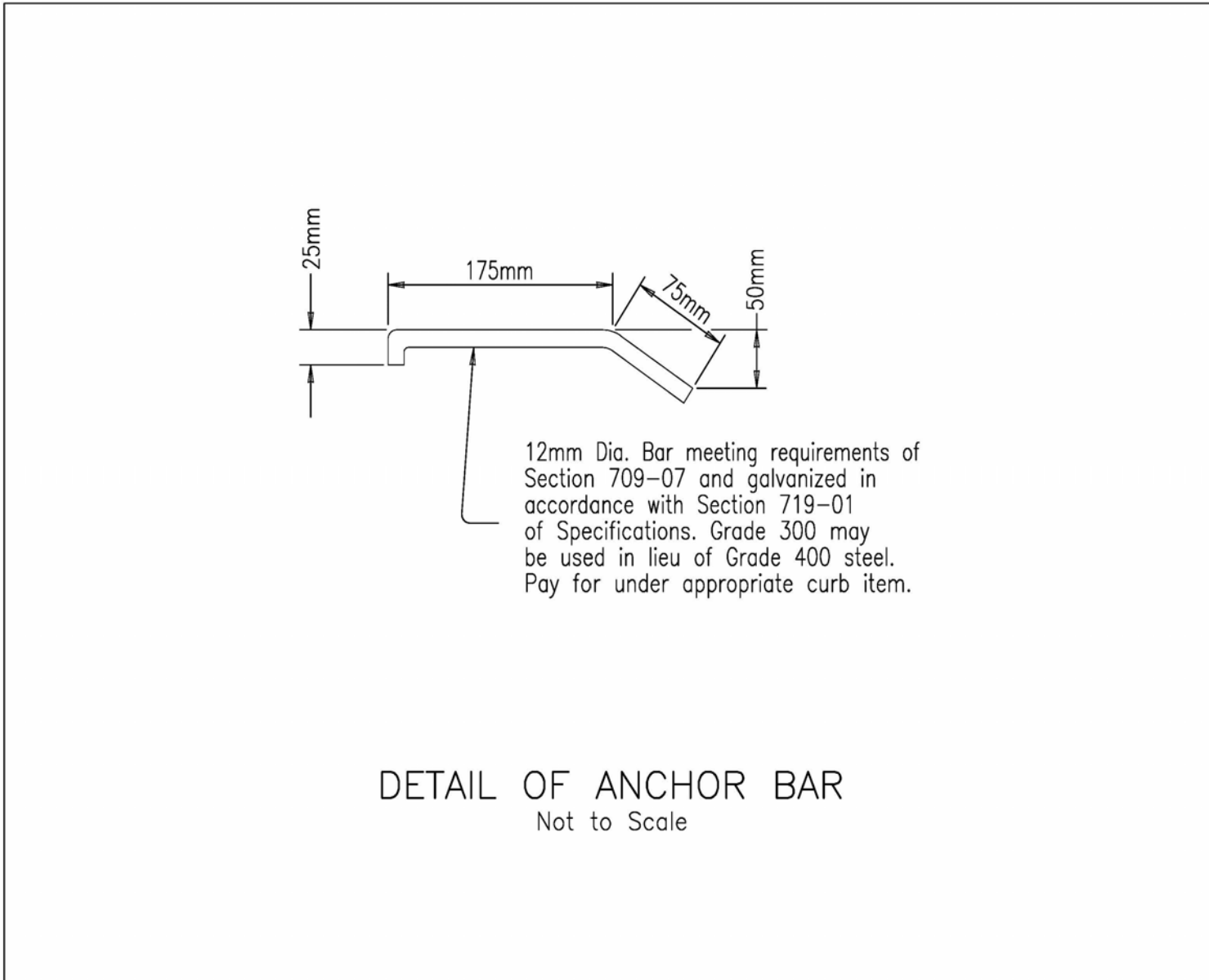

C9-5

